

SLICING

Berkel**330M**
HERITAGE PROSCIUTTO SLICER

Model 330M

**FEATURES**

Berkel Model 330M Heritage Prosciutto slicer features Berkel's hollow ground chromium-plated, carbon steel knife and built-in, single lever, dual-action sharpener. This slicer is perfect for ultra thin slicing in front of customers. The fly-wheel allows for precision slicing, every stroke. The product is automatically fed towards the knife after each stroke. A rear ring guard protects the non-slicing portion of the knife. The product clamp holds the meat from the top, ensuring that it is held securely. The 330M is easy to clean and disassembles quickly without tools.

- 330M** Manual Fly Wheel Slicer

STANDARD FEATURES

- Low resistance fly-wheel for smooth, easy slicing.
- Rear knife guard.
- Classic styling with the "traditional" Berkel red color.
- Integrated two stone sharpener.
- 13" hollow ground knife.
- Clamping device for solidly holding the product.
- Automatic feeding of the product into the knife.
- Handles product 7³/₄" high by 11" wide.
- Slices product 7³/₄" round.
- Slicing up to ³/₁₆" in thickness.

ACCESSORIES (Packaged & Sold Separately)

- Stand:
- 330MSTAND (Pedestal)



- 330M-STANDC (with Casters)



The 330M is the gold standard for "front-of-the-house theatre slicing"

Berkel

a division of ITW Food Equipment Group LLC

Berkel**330M**
HERITAGE PROSCIUTTO SLICER**SPECIFICATIONS**

Finish/construction: All food contact areas are stainless steel, anodized aluminum or painted including the pusher, gauge plate, product table, center plate, knife ring guard and one-piece base. Slicer disassembles quickly without tools for easy cleaning.

Knife: Nominal 13" (330 mm) diameter, hollow ground, hardened and polished forged chromium-plated carbon steel.

Cutting Capacity: Carriage handles food up to 7 $\frac{3}{4}$ " (200 mm) wide by 11" (280 mm) high or 7 $\frac{3}{4}$ " (200 mm) diameter.

Slice Thickness: Precision system provides infinite slice adjustment and consistent cuts of hot or cold meats and cheese from tissue thin to $\frac{3}{16}$ " (5 mm).

Knife Sharpener: Integral top mounted, two stone, dual-action system for a lasting, razor-sharp edge.

Knife Ring Guard: Rear guard covers non-slicing portion of knife edge.

Manual Operation: No motor.

Warranty: All parts, service and travel coverage for one year, excluding wear items.

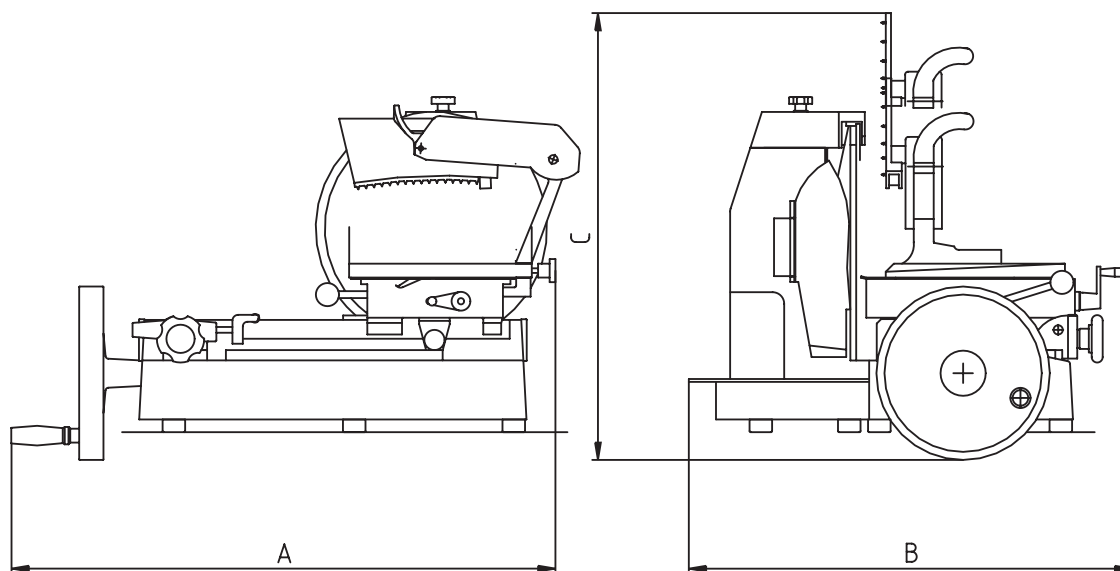

MODEL NO.	CUTTING CAPACITY	SLICE THICKNESS	KNIFE DIAMETER	PRODUCT DIMENSIONS		
				DEPTH A	WIDTH B	HEIGHT C
330M	11" (280 mm) wide 7 $\frac{3}{4}$ " (200 mm) high 7 $\frac{3}{4}$ " (200 mm) diameter	to $\frac{3}{16}$ " (5 mm)	13" (330 mm)	33 $\frac{1}{2}$ " (850 mm)	26 $\frac{1}{2}$ " (670 mm)	25" (635 mm)

MODEL NO.	FEET WIDTH	FEET LENGTH	WEIGHT		BOX DIMENSIONS		
			NET	SHIP	DEPTH A	WIDTH B	HEIGHT C
330M	15 $\frac{3}{4}$ " (400 mm)	23" (585 mm)	140 lbs. (64 kg)	192 lbs. (87 kg)	32" (815 mm)	40" (1020 mm)	40" (1020 mm)

Berkel a division of ITW Food Equipment Group LLC

P.O. Box 696 ■ Louisville, KY 40201 ■ Toll-free: 1-800-814-2028 ■ Local: 502-778-2791 ■ Quote & Order Fax: 1-800-444-0602